



DLR  
NLR  
FOI  
ONERA  
FZK  
BUW  
MMU  
USFD  
UiO  
EBI  
NTUA  
UP  
NKUA

# ECATS

## Environmentally Compatible Air Transport System



# ECATS Objectives

- Re-structuring and re-organisation of research organisations and universities in Europe and preparing the ground for a European Virtual Institute for Research on the **Environmental Compatibility of Aviation**
  - integrating related areas of technology and atmospheric science
  - integrating competences and capacities of partner organisations
  - aiming for a common research programme
  - extending capabilities to be more competitive
  - offering one point of contact for stakeholders
- Research Establishments and Universities within Europe



# ECATS Partners



13 partners from 7 countries

★ 5 Research Establishments

★ 8 Universities

Budget: 7 Mio €

Duration: 5 years

Start: 15 Jan 2005

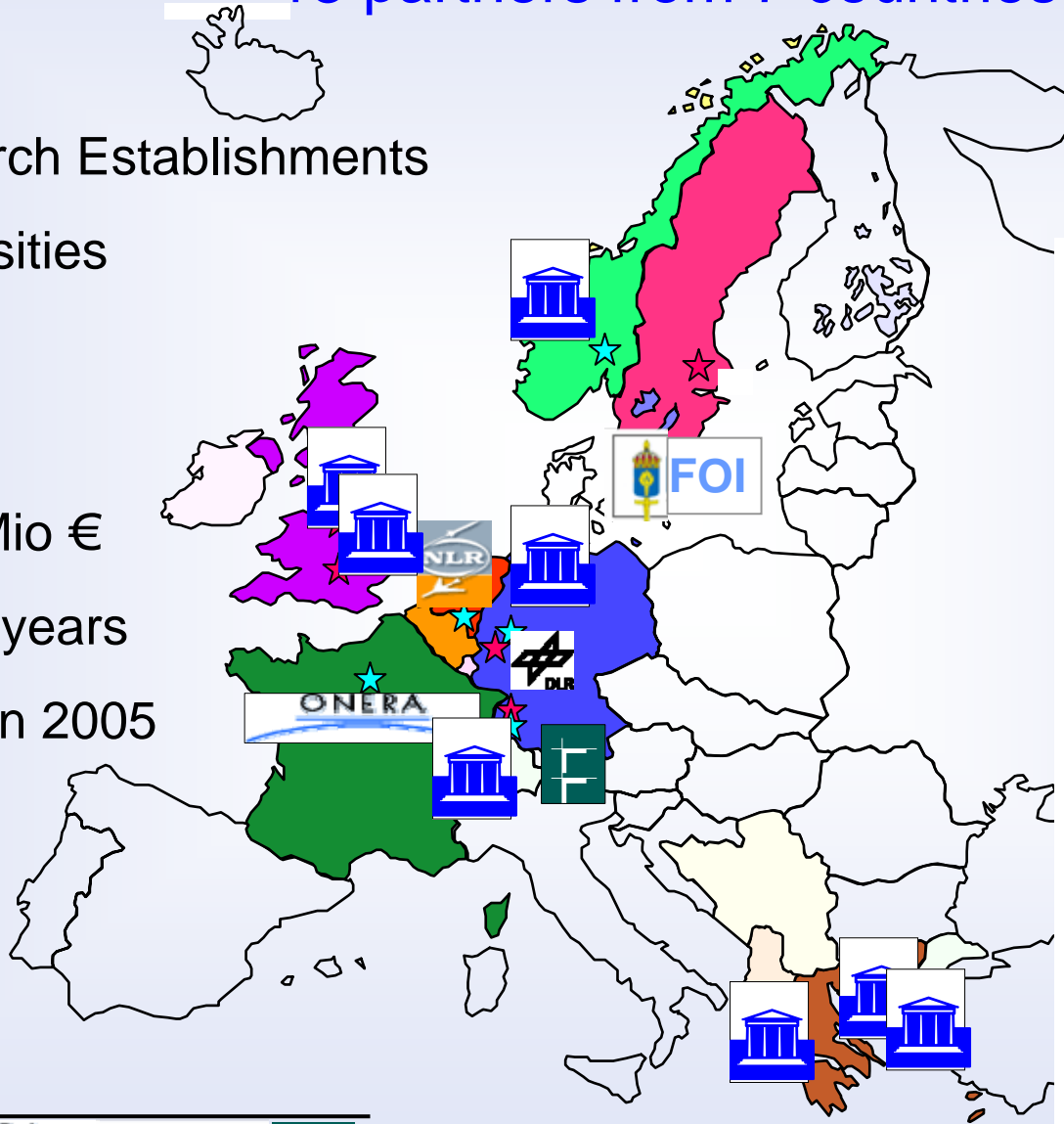

- DLR (D)
- NLR (NL)
- ONERA (F)
- FOI (S)
- FZK (D)

## Universities

- Wuppertal (BUW)
- Karlsruhe (EBI)
- Manchester (MMU)
- Sheffield (USFD)
- Oslo (UiO)
- Athens (NTUA)
- Patras (UP)
- Athens (NKUA)



June 2006  
Aerodays 2006, Vienna



# ECATS Partners



## 13 partners from 7 countries

★ 5 Research Establishments

★ 8 Universities

*100 Researcher*

Budget: 7 Mio €

Duration: 5 years

Start: 15 Jan 2005

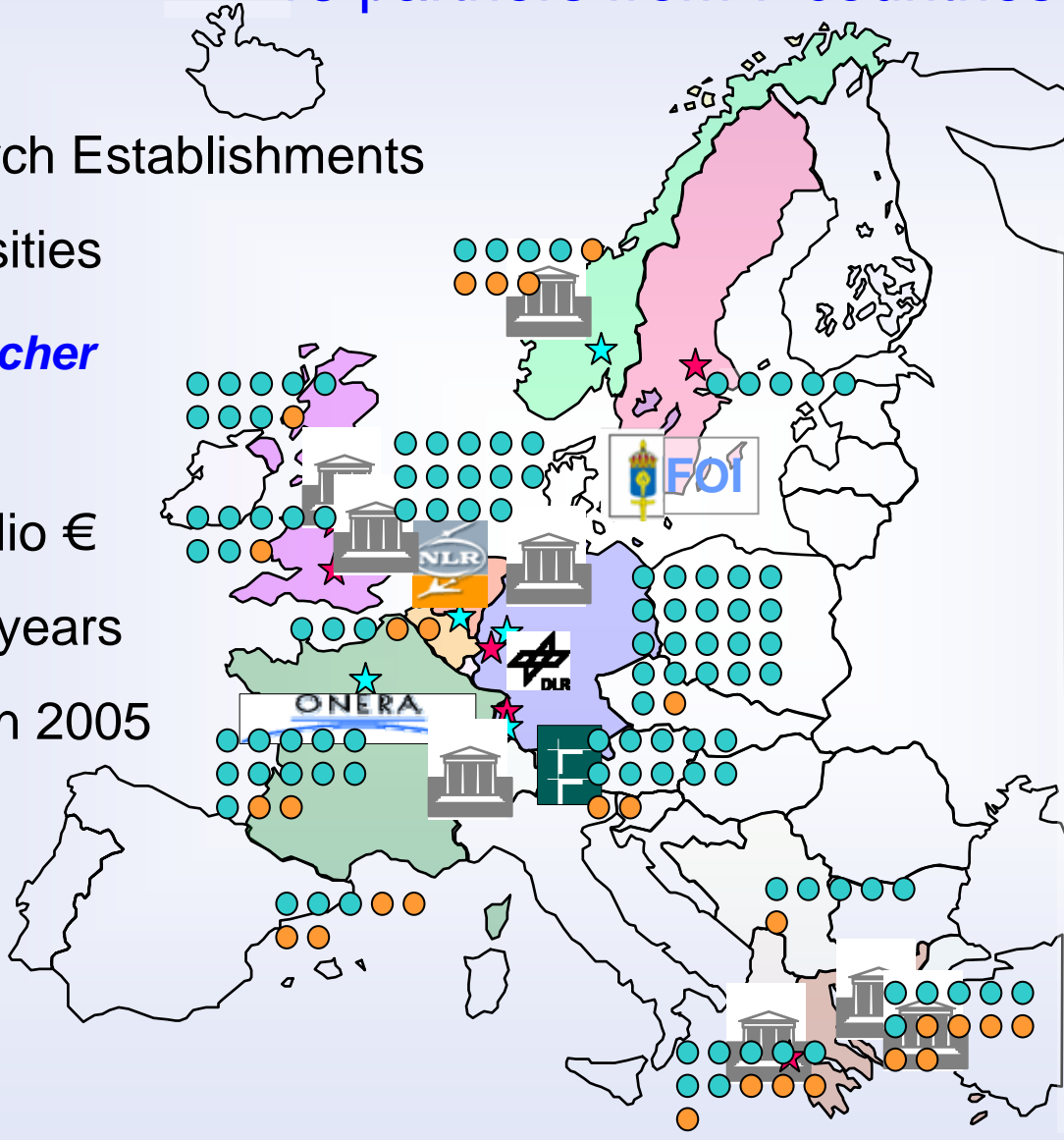

- DLR (D)
- NLR (NL)
- ONERA (F)
- FOI (S)
- FZK (D)

### Universities

- Wuppertal (BUW)
- Karlsruhe (EBI)
- Manchester (MMU)
- Sheffield (USFD)
- Oslo (UiO)
- Athens (NTUA)
- Patras (UP)
- Athens (NKUA)

June 2006

Aerodays 2006, Vienna





# ECATS - Network of Excellence

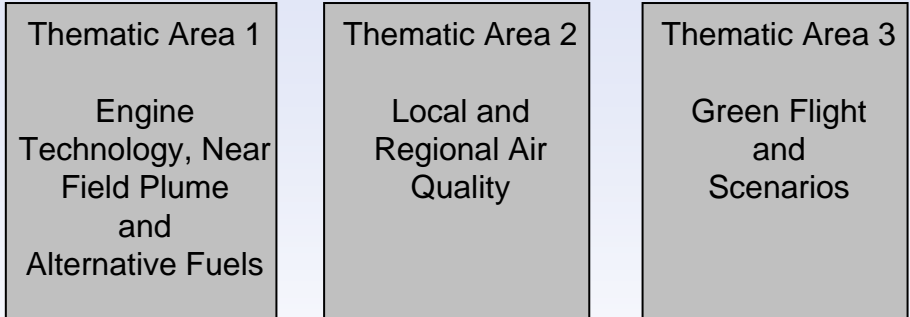

**Integrating Activities**

**Jointly executed research**

**Spreading of Excellence**

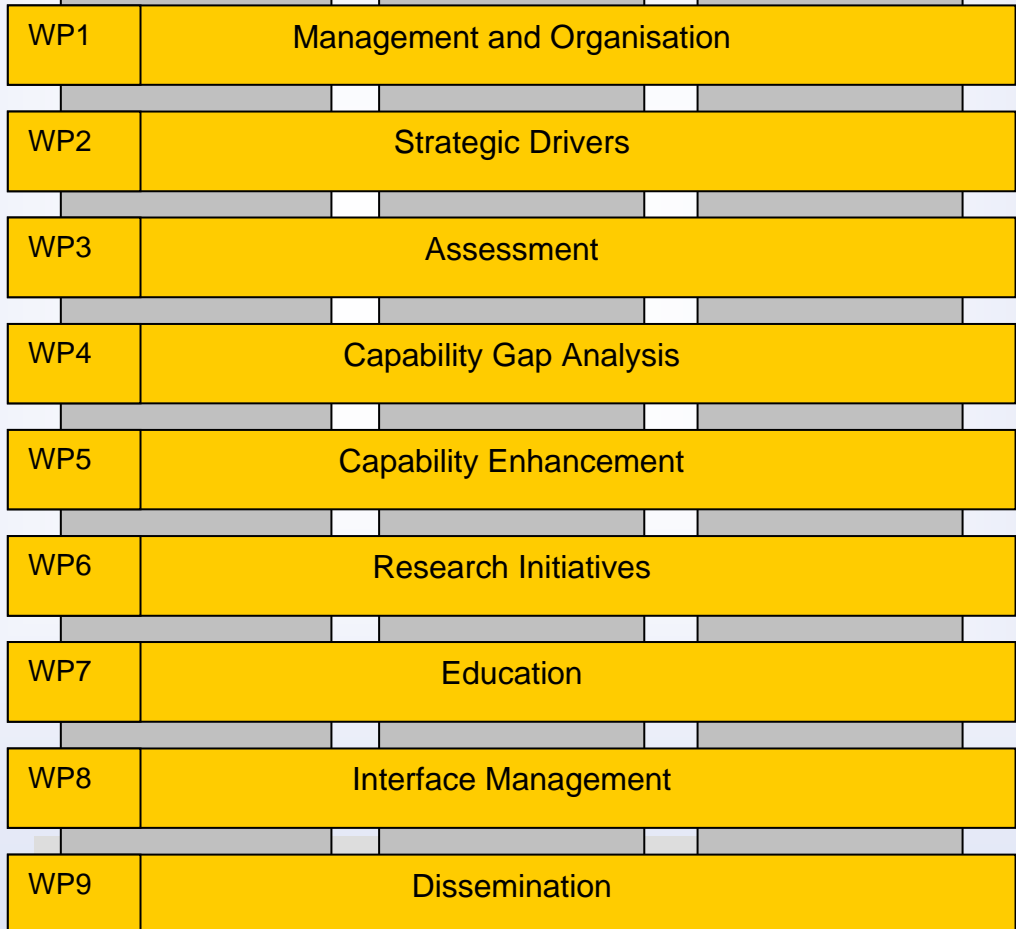

**DLR**

**NLR**

**ONERA**

**ONERA**

**USFD**

**DLR**

**MMU**

**MMU**

**FOI**





# ECATS Structure

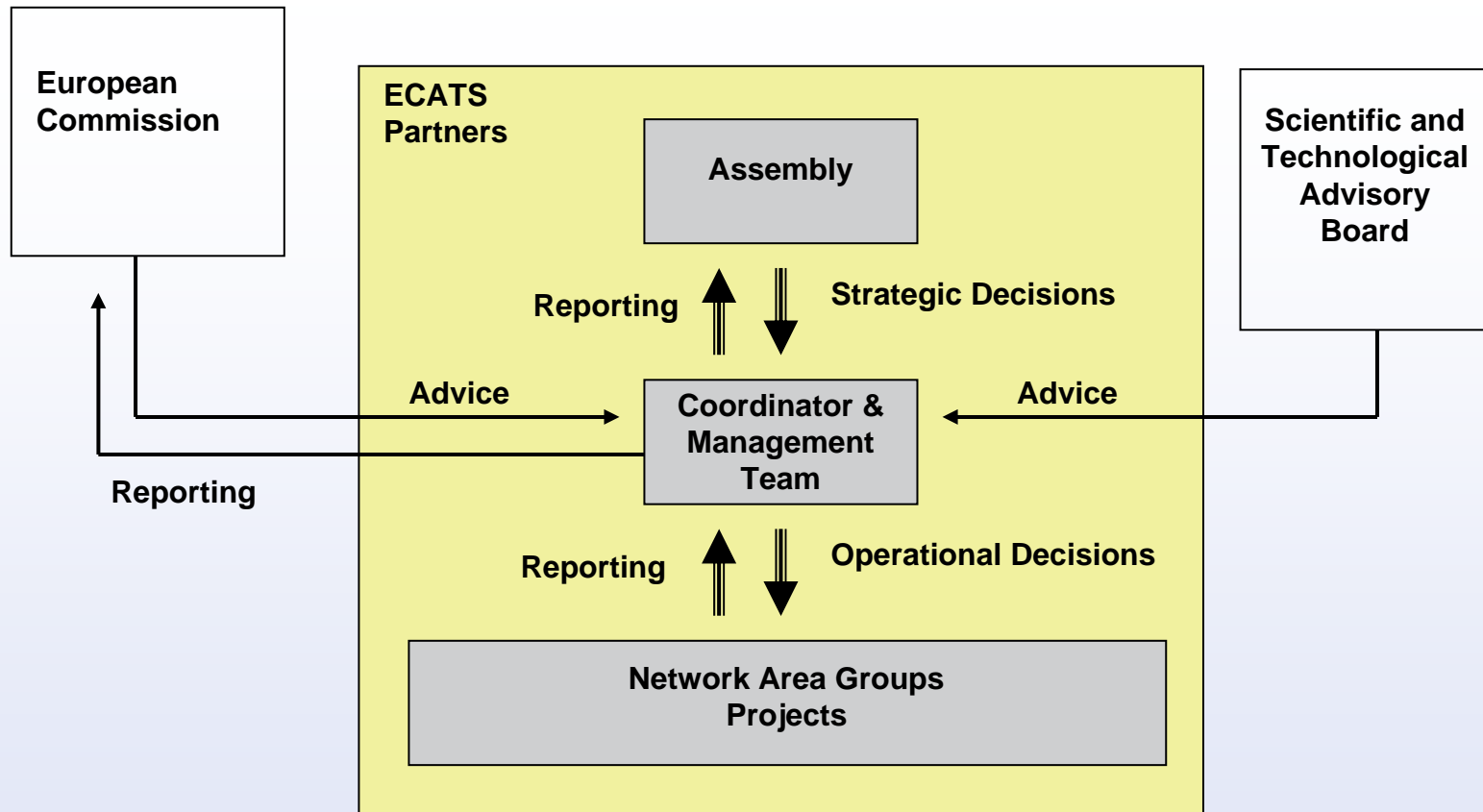



# WP1 on Integration



Area	Progress during first year	Objective
Network Office	<ul style="list-style-type: none"><li>• Network Office established</li><li>• Network Activities (Mt, WS)</li></ul>	Joint office
Programme Management	<ul style="list-style-type: none"><li>• Programmatic structures assessed</li></ul>	Joint research programme
Infrastructure	<ul style="list-style-type: none"><li>• List of available infrastructure</li><li>• Thematic Workshop</li></ul>	Joint use of infrastructure
Personnel Mobility	<ul style="list-style-type: none"><li>• Procedures established</li><li>• Discussion on key issues</li></ul>	Foster and facilitate
Intellectual Property	<ul style="list-style-type: none"><li>• List of PEKH</li><li>• First requirements identified</li></ul>	Common knowledge portfolio



# WP2 on Strategic Drivers Aviation & Environment system

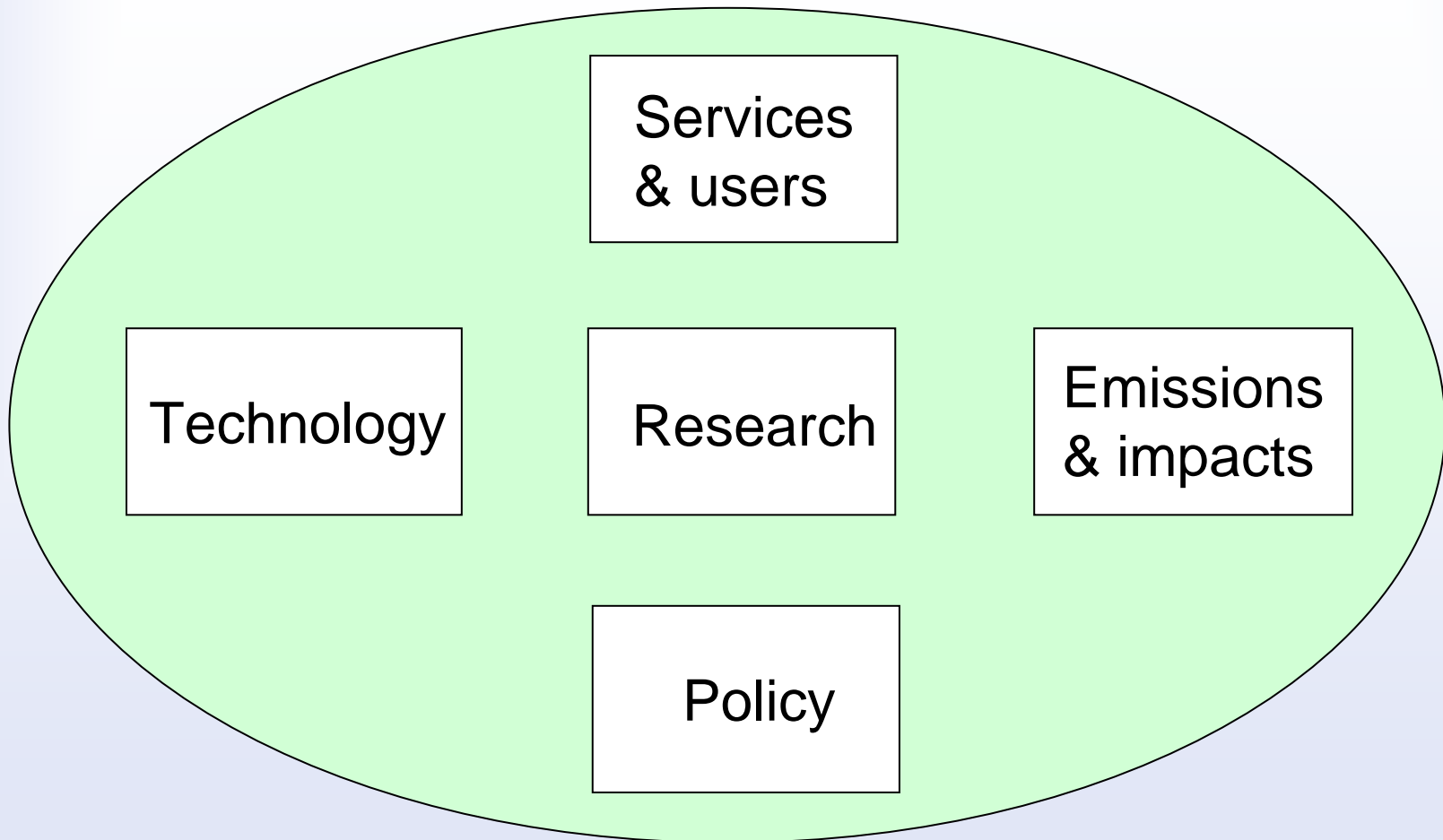



## SCIENTIFIC AND TECHNICAL COVERAGE of Expertise within the Network

### **TA1**

Cycles  
Combustors technology  
Combustion modelling  
Gaseous emissions  
Soots  
Aerosols  
Properties of fuels  
Fuel stability  
Alternative fuels  
Physicochemistry of the jet  
Jet-wake interaction

### **TA2**

Emissions inventories  
Impact on local air quality  
Impact on global air quality  
Airport air quality  
Experimental data acquisition  
Physicochemistry of the atm.  
Layering of the atmosphere  
Regional climate modelling  
Urban air quality  
Creation of databases  
Participation to regulation

### **TA3**

Scenarios  
Strategy development  
Evolution of air transport  
Flight procedures  
Safety  
Airport operations  
Air traffic management  
Impact on air quality  
Altered flight procedures



# EXAMPLES OF POTENTIAL IMPROVEMENTS AND REQUIREMENTS

## **TA1**

Decrease emissions  
Improve emissions character.  
VOC speciation  
organic matters  
Additives  
Cirrus from contrails  
Aerosols and ice formation  
Alternative fuels impact  
Standard of soot measures

## **TA2**

Better knowledge of sources  
Evaluation capacity  
Impact estimation  
Sources attribution  
Measurement strategies  
Nanoparticles measurements  
Harmonization of AAQ models  
Monitoring and instrumentation  
Databases

## **TA3**

Impact minimization  
Revised operational condit.  
Altered flight procedures  
Trade-off between emissions,  
operations and ATM  
Trade-off between technology  
and operational procedures



# Results from WP 4: Examples of topics within the Network

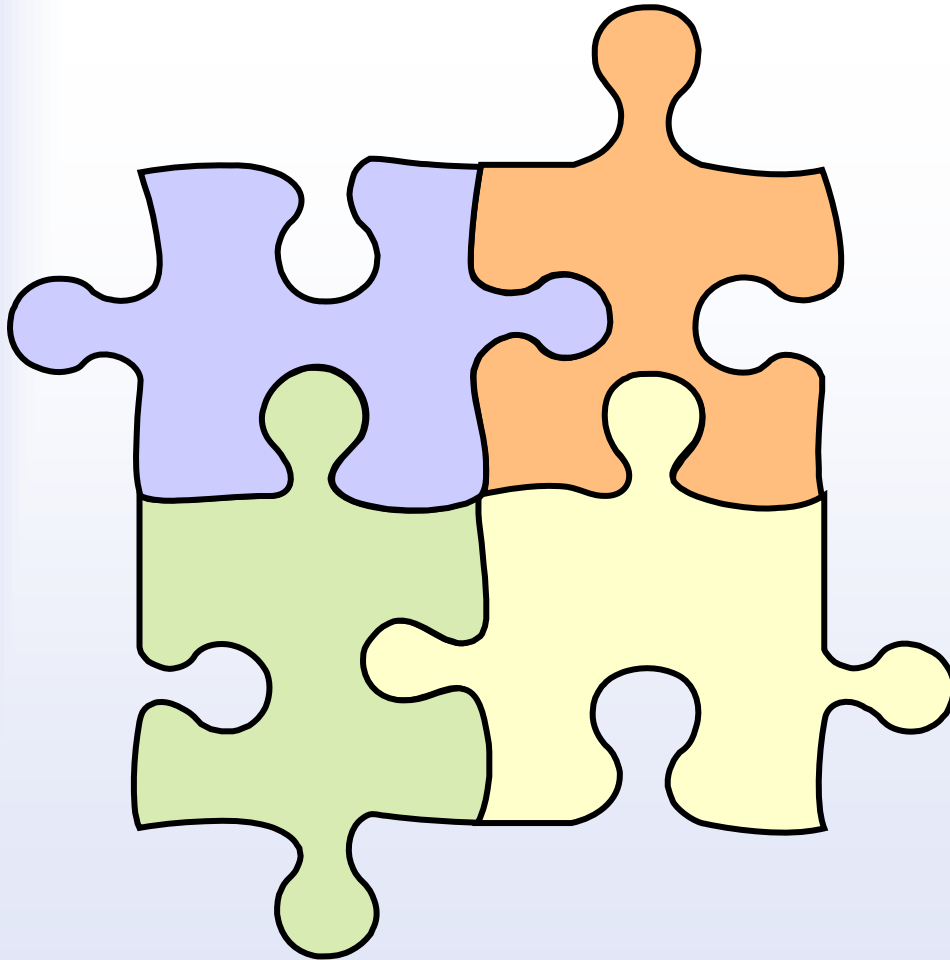

- Trade-off between noise and emissions  
⇒ Task established

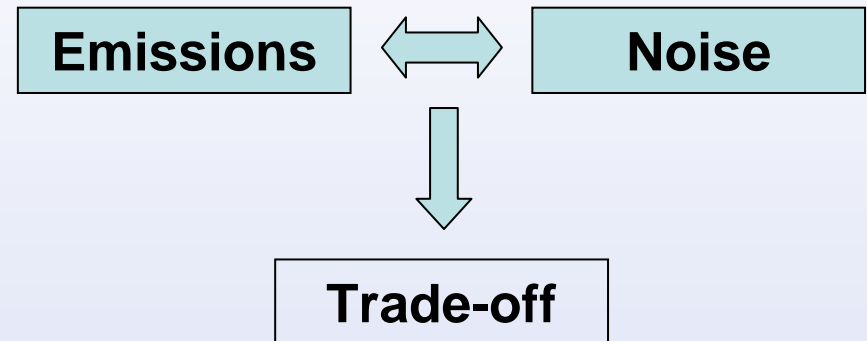



# ECATS - Network of Excellence

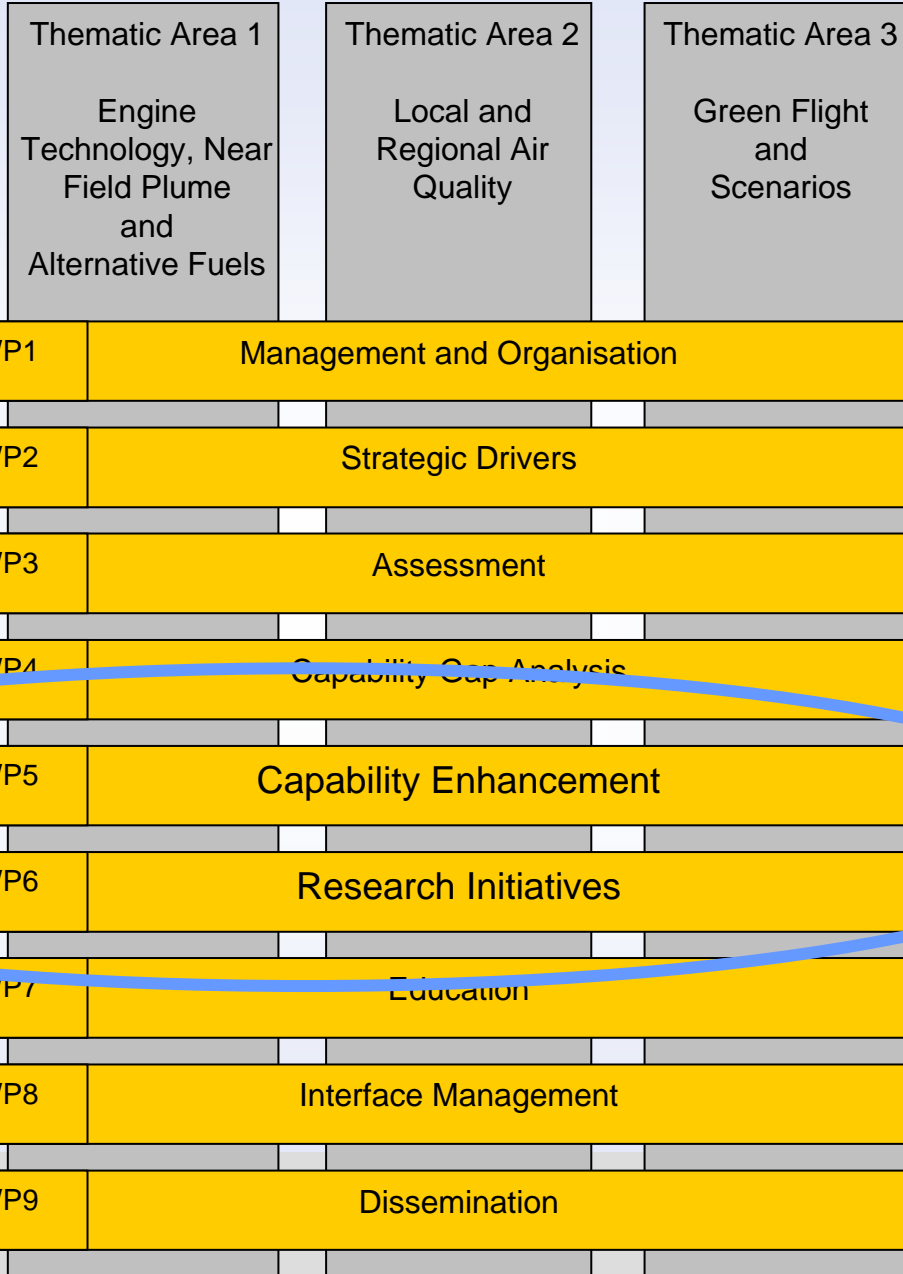

**Integrating Activities**

**Jointly executed research**

**Spreading of Excellence**

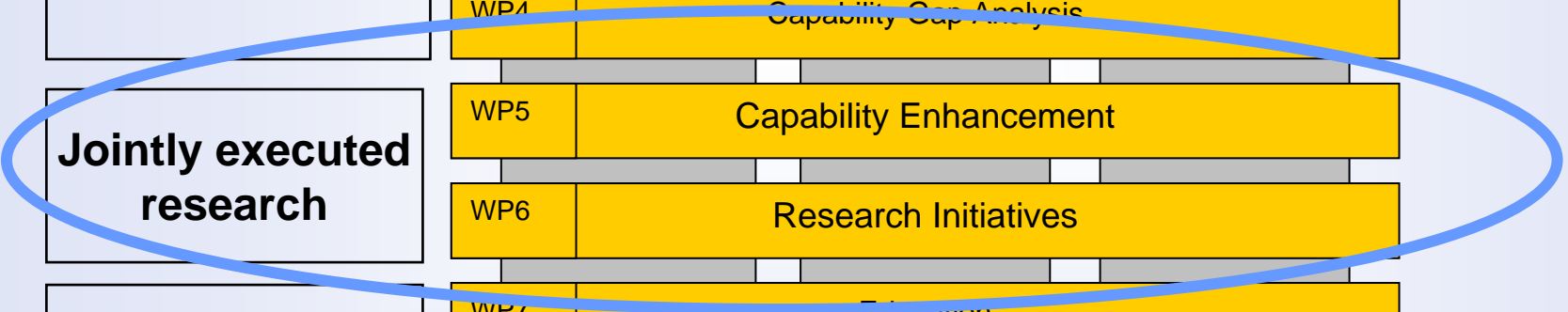



# Jointly executed research



- NoE needs vehicles to promote integration  
⇒ **Jointly executed research**

- Airport Air Quality
- Trade-off emissions / noise
- Technology impact on contrail and contrail-cirrus





# Jointly executed research

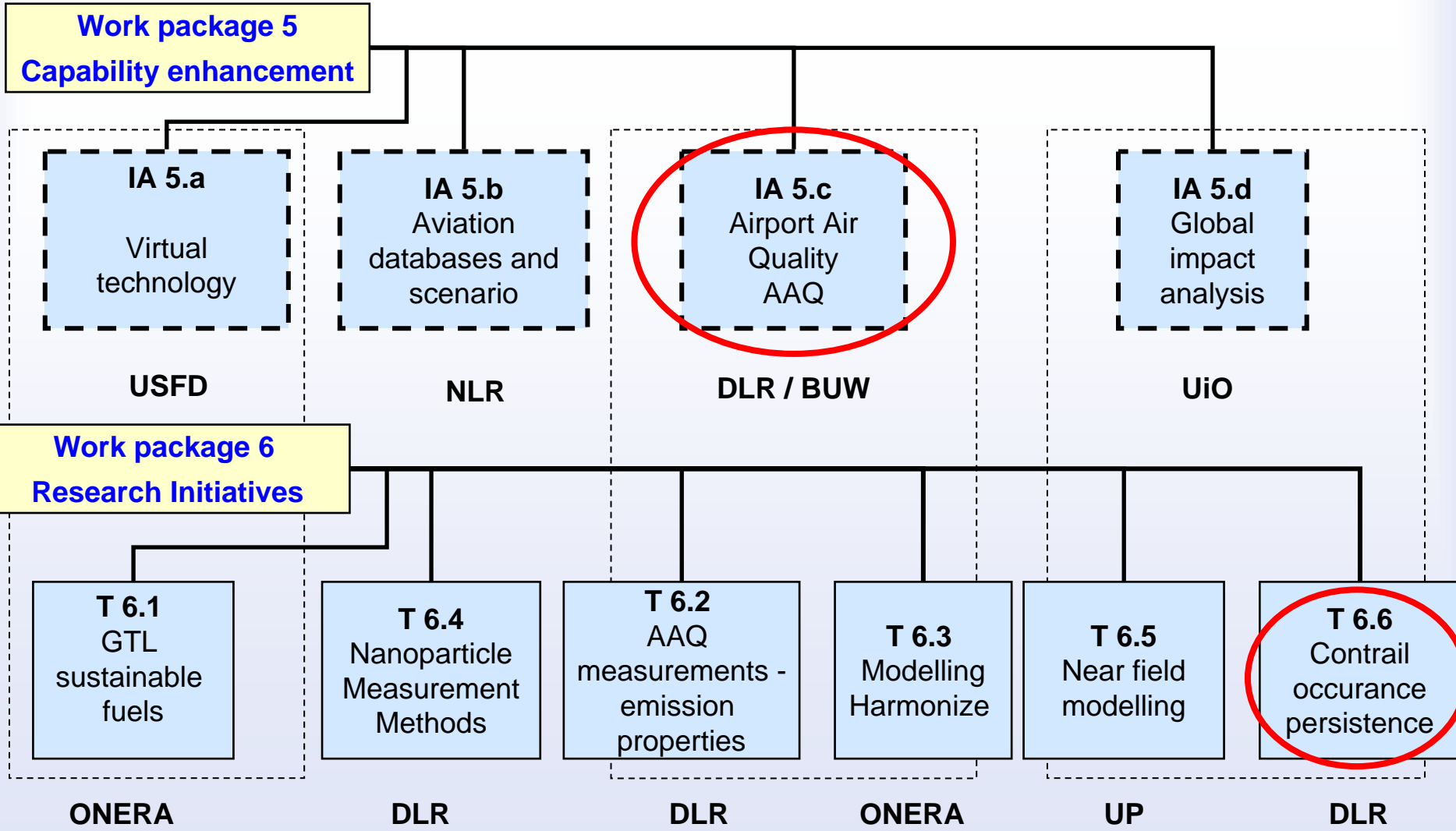



# Task 5.c Airport Air Quality

## Emission Inventories

Gas turbine performance / combustor emission modelling

real-world emissions

ATM

## Modelling

Chemical mechanism

Plume dynamics

Atmospheric model

airport scale

meso-scale

## Measurements

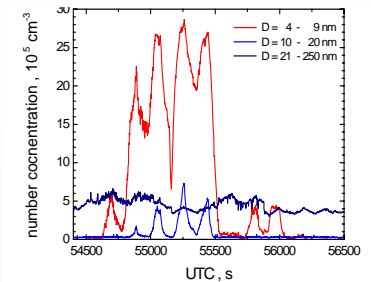

Analyse options, measures and strategies to reduce impact

++ strongly fragmented ++ research required ++ joint effort required ++



# Contrails occurrence and persistence



## Line-shape Contrail identification in satellite observations

UTC 2004/08/31 16:30 EUMETSAT, DLR Oberpfaffenhofen IPA

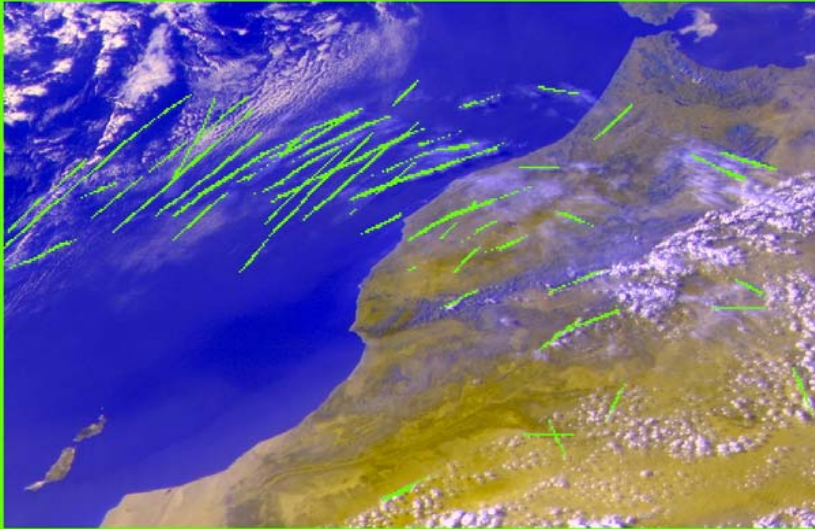

## Vortex evolution on different scales

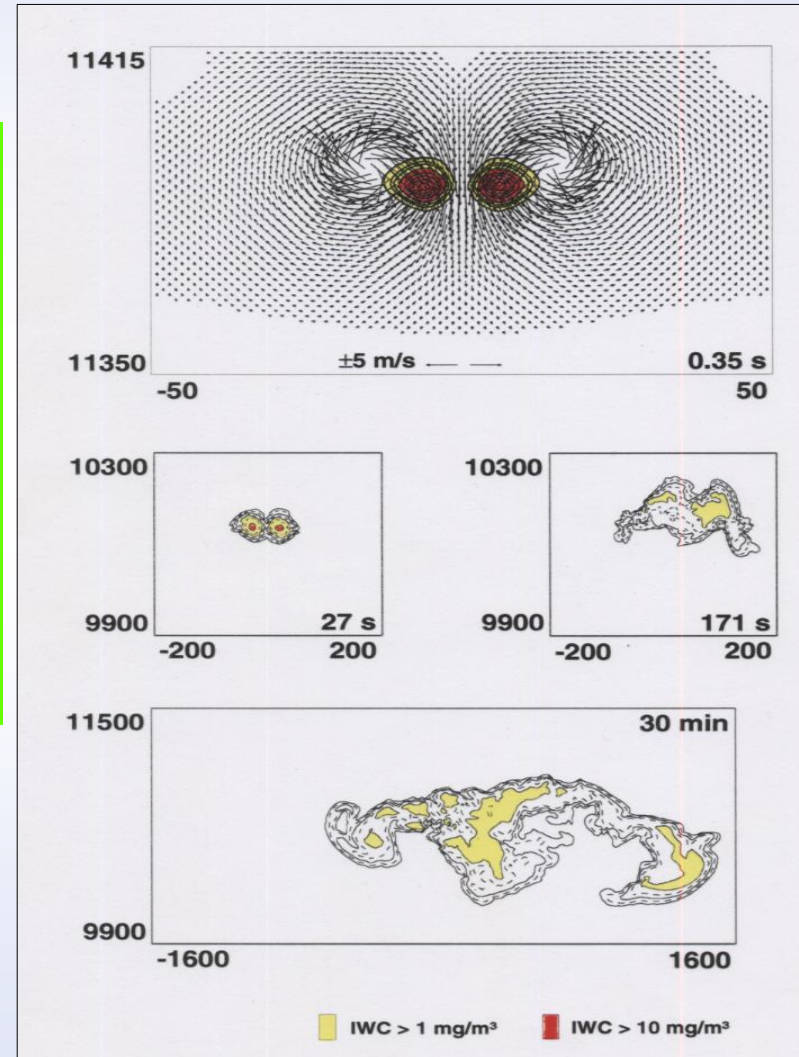

Jet phase,  $t < 20s$

Vortex phase,  $t < 2 \text{ min}$

Dispersion phase,  $t > 2 \text{ min}$

June 2006

Aerodays 2006, Vienna

Slide 16 / 19



# *Spreading of Excellence*



## WP 7 Education

- Programmes & Platforms  
strategies & best practice & summer schools & e-based

## WP 8 Interface Management

- ◆ Stakeholders
- ◆ Expertise outside the network

## WP 9 Dissemination

- Internal Communication
  - ◆ efficient & replace email exchange
  - ◆ establish internal web-based platform
- External Communication
  - ◆ stakeholders & general public



# Where will ECATS be at the end of the project

## Pre-requisites and Pre-conditions to set up a European Virtual Institute

- Common research programme and activity planning
- Joint research groups and projects
- Common planning for use of existing infrastructure
- In single cases: set up of ECATS infrastructure
- Clear definition and analysis of legal options for a legal entity ECATS
- Financing models to continue activities and to finance the ECATS network office beyond community funding within this legal entity



**Thank you !**



## **Coordinator:**

Dr. Sigrun Matthes, DLR

Email: [sigrun.matthes@dlr.de](mailto:sigrun.matthes@dlr.de)

## **Network Office**

Alvaro Tejero, DLR

Phone: +49 8153 28 1108

Fax: +49 8153 28 1841

<http://www.pa.op.dlr.de/ecats>

<http://www.ecats-network.eu>

## **Project Officer**

Dr. Dietrich Knoerzer

Email: [dietrich.knoerzer@cec.eu.int](mailto:dietrich.knoerzer@cec.eu.int)